

# SOLENOÍDE/ SOLENOID SWITCH / SOLENOIDE

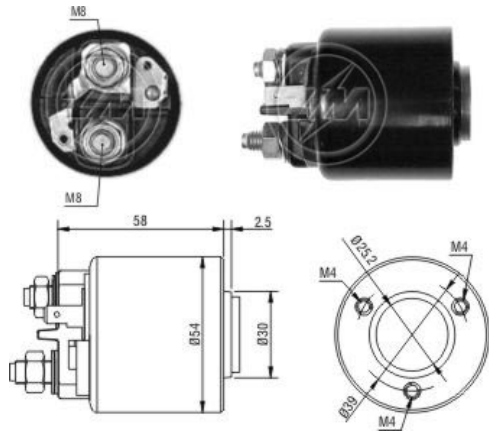

**Solenóide ZM 491 12v**

**CAP ZM 597.91**

**Código Original do Solenóide / Solenoid Original Code / Código Original del Solenoide**

**PARIS RHONE:**

594045  
CED552  
NE777

**VALEO:**

594045  
CED552  
NE777

**Código do Motor / Starter Code / Código del Motor**

**VALEO:**

D6RA10  
D6RA13  
D6RA15  
D6RA20  
D6RA42  
D6RA5  
D6RA7

**Aplicação / Used on / Aplicacion**

Montadora / Car Maker	Veículo / Vehicle	Variação do modelo / Model variation:	De / From:	Até / To:	
CITRO	AX	1.0 with C1A-C3A engine	1986	1991	
		1.0i with CDY-CDZ engine	1992		
		1.1 with HAZ-H1A-H1B engine	1986	1991	
		1.1i with HDZ engine	1989		
		1.3 Sport with M 4A engine	1987	1988	
		1.4 with K1F-K1G engine	1988		
		1.4 with KAY-K1B-K1A engine	1986		
		1.4 GT with K2A-K2B engine	1987		
		1.4i with KDX, Y, Z-K2D-KFZ-K6B engine	1990		
		Berlingo	1.1i with HDZ (TU1M) engine	1996	
			1.1i with HDZ (TU1M) HFX engine	1996	
		BX	1.4i with KFX (TU3JP) engine	1996	
			11	1986	1992
			14 with K1H engine	1988	
	14 with K1H (TU3A) engine		1989		
	14 with KDY (TU3M)/ KDZ (TU3M/Z) engine		1989	1993	
	14 E with 150A engine		1988		
	C15	14 E with 150C engine	1988		
		14 E with 150F engine	1988		
		1.4 E with K3A engine	1987	1996	
		1.4i with KDY (TU3M), KDY(TU3FM) engine	1991	1996	
		1.1i with HDZ (TU1M) engine	1988	1996	
		1.4 with K1H (TU3A) engine	1987	1996	
	Saxo	1.4 E with 150D (XY7) engine	1987	1996	
		1.0 X with CDZ (TU9M) engine	1996		
		1.1 X with HDZ (TU1M) engine	1996		
		1.1 SX with HDZ (TU1M) engine	1996		
		1.1 X with HDZ (TU1M)/ HFX engine	1996		
1.1 SX with HDZ (TU1M)/ HFX engine		1996			
1.4 VTS with KFW (TU3JP)/ KFX (TU3JP) engine		1996			
1.6 VTR with NFZ (TU5JP) engine		1996			
1.6 VTL with NFZ (TU5JP) engine		1996			
1.6 VTS with NFX (TU5JP4) engine		1996			
Xsara	1.6i with NFZ (TU5JP) engine	1997	2000		
	Break 1.6i with NFZ (TU5JP) engine	1997	2000		
ZX	1.1	1991			
	1.1i	1991			
	1.4	1991			
	1.4i	1991			
	1.6i with BFZ,BDY,B4A engine	1991			
	1.8i with LFZ, L6A engine	1992			
PEUGEOT	106	II 1.0i with CDZ (TU9M) engine	1997		
		II 1.1i with HDY (TU1M) engine	1997		
		II 1.1i with HDZ (TU1M), HFX engine	1996		
		II 1.4i with KFW/ KFX (TU3JP) engine	1996		
		II 1.4i with TU3FM, TU3M, TU3FJ engine	1991		
		II 1.6i with NFW (TU5J2), NFY (TU5J2) engine	1996		
		II 1.6i with NFZ (TU5JP) engine	1996		
		II 1.6 S16 with NFX (TU5J4) engine	1996		
		I 1.0 with CDY (TU9M) engine	1991	1996	
		I 1.0 with TU9, TU9M engine	1991		
		1.0	1991	1996	
		1.0i with TU9, TU9M engine	1991		
		1.1 with HDZ (TU1M) engine	1991	1996	
		1.1 with TU1, TU1M engine	1991		
		1.1i with TU1, TU1M engine	1991		
		1.3 with TU2J2 engine	1991	1996	
	1.4 with KDX (TU3MC), KDY (TU3M) engine	1991	1996		
	1.4 with KFZ (TU3J2/Z) engine	1991	1996		

		1.4 with TU3, TU32 engine	1991	
		1.6 with NFY (TU5J2) engine	1994	1996
		1.6 with NFZ (TU5JP) engine	1993	1996
	205	II 1.1 with TU1 engine	1987	
		II 1.3 with TU24 engine	1987	
		II 1.3 Rallye with TU24 engine	1987	1990
		II 1.4 with K1D (TU3A) engine	1987	1990
		II 1.4 with K2B (TU3S) engine	1987	1989
		II 1.4 with KDY (TU3M) engine	1988	1998
		II 1.4 with KDZ (TU3M) engine	1988	1998
		II 1.4 with KFX (TU3JP) engine	1988	1998
		II 1.4 with TU3 engine	1987	
		II 1.4 with TU3S engine	1987	
		I 1.0 with TU9 engine	1987	
		II Cabriolet 1.4 with TU3 engine	1987	
		I Cabriolet 1.0 with TU9 engine	1987	
		II Cabriolet 1.4 with TU3CP engine	1987	
		I Cabriolet 1.1 CJ with HDZ (TU1M) engine	1989	1994
		II Cabriolet 1.4 with 3S engine	1987	
		I Cabriolet 1.4 CJ with 150D (XY7) engine	1988	1989
		II Cabriolet 1.4i with TU3M engine	1988	
		I Cabriolet 1.4 CJ with 150G (XY7) engine	1988	1989
		I Cabriolet 1.4 CJ with K1D (TU3A) engine	1989	1994
		I Cabriolet 1.4 CJ with KAY (TU3CP) engine	1989	1993
		I Cabriolet 1.4 CJ with KDY (TU3M) engine	1991	1994
		I Cabriolet 1.4 CJ with KDZ (TU3M) engine	1991	1994
		II 1.0 with TU9 engine	1987	1998
		II 1.1 with H1B (TU1) engine	1987	1990
		II 1.1 with HDZ (TU1M) engine	1989	1998
	206	1.1i with HFX (TU1JP) engine	1998	
		1.1i with HFZ (TU1JP) engine	1998	
		1.4i with KFX (TU3JP) engine	1998	
	306	1.4i with TU32 engine	1993	
		1.4i with TU3M/C engine	1993	
		1.4 SL with KDX (TU3MC) engine	1994	
		1.4 SL with KFW engine	1994	
		1.4 SL with KFX (TU3JP) engine	1994	
		1.6 with NFZ (TU5JP) engine	1993	2000
		1.6 SR with NFZ (TU5JP) engine	1994	2000
		1.6i with TU5JP engine	1993	
		Break 1.4 with KFW/ KFX (TU3JP) engine	1997	2000
		Break 1.6 with NFZ (TU5JP) engine	1997	
		Cabriolet 1.6 with NFZ (TU5JP) engine	1996	2000
		1.1 with HDZ (TU1M) engine	1993	
		1.1i with TU1M engine	1993	
		1.4 with KDX (TU3MC) engine	1993	
		1.4 with KFW engine	1993	
		1.4 with KFX (TU3JP) engine	1993	
		1.4 with TU3 engine	1993	
		1.4 with TU32 engine	1993	
		1.4 with TU3M/C engine	1993	
		1.4i with TU3 engine	1993	
	309	II 1.4 with K1D (TU3A) engine	1989	1989
		II 1.4 with K2B (TU3S) engine	1989	1989
		II 1.4 with KDY (TU3M) engine	1989	1989
		II 1.4 with KDZ (TU3M) engine	1989	1989
		II 1.1 with HDZ (TU1M) engine	1990	1993
		II 1.1 with TU1 engine	1989	1992
		II 1.4 with K1D (TU3A) engine	1990	1993
		II 1.4 with KDY (TU3M)/ KDZ (TU3M) engine	1989	1993
		II 1.4 with TU3 engine	1991	1993
		II 1.4i with TU3 engine	1991	1993
	405	I 1.4 with TU3 engine	1987	1993
		I 1.4 with TU3A engine	1987	1993
		I 1.4i with TU3 engine	1987	1993
		I 1.4i with TU3A engine	1987	1993
		II 1.4 with KDX (TU3MC) engine	1992	1995
		Break 1.4 with KDX (TU3MC) engine	1992	1996
	Partner	1.1 with HDZ (TU1M) engine	1996	
		1.4 with KFX (TU3JP) engine	1996	
		Combispace 1.1 with HDZ (TU1M)/ HFX engine	1996	
		Combispace 1.4 with KFX (TU3JP) engine	1996	
<b>Montadora / Car Maker</b>	<b>Veiculo / Vehicle</b>	<b>Variação do modelo / Model variation:</b>	<b>De / From:</b>	<b>Até / To:</b>